

CAPACITY	SYMBOL/SERIAL NO.	CIRCUIT DIAGRAM
AC100~240V, 50/60Hz		
12.5W x 2		

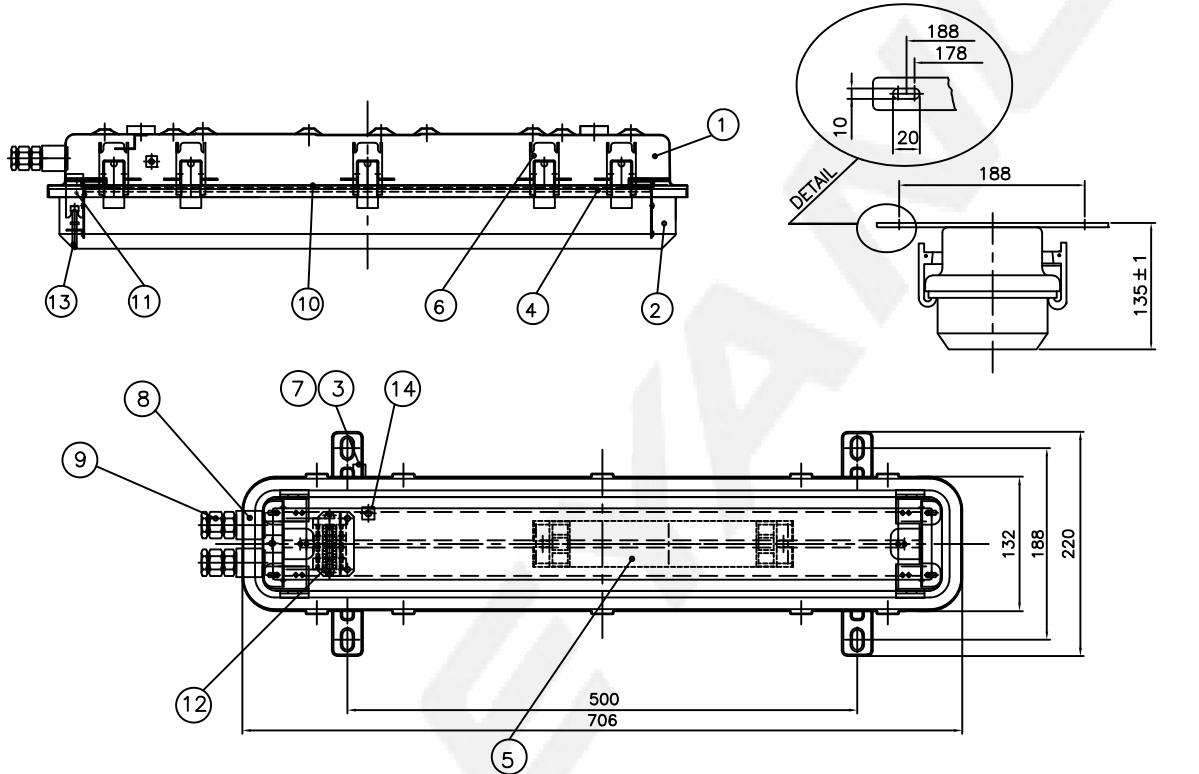

CIRCUIT DIAGRAM

SETTING DIMENSION

14	INSIDE EARTH BOLT	STAINLESS STEEL316	1		7	OUTSIDE EARTH BAR	STAINLESS STEEL316	1	
13	INTERLOCK SHAFT	BRASS	1		6	LATCH	STAINLESS STEEL316L	10	
12	TERMINAL BLOCK	-	1	CLAMPING 4P	5	LED driver	-	1	
11	INTERLOCK SWITCH	-	1		4	LED module	-	2	5,000±300K
10	REFLECTOR	STEEL	1		3	OUTSIDE EARTH BOLT	STAINLESS STEEL316	1	M6
9	CABLE GLAND(M20)	BRASS	2	OS-E1UF 16 (ø9~15.5)	2	GLOBE	POLYCAR-BONATE	1	
8	GLAND HUB(M20)	STAINLESS STEEL316	2		1	BODY	STAINLESS STEEL316L	1	
NO	NAME OF PART	MATERIAL	Q'TY	REMARKS	NO	NAME OF PART	MATERIAL	Q'TY	REMARKS

APPROVED	B. K. KIM	UNIT	MM	TITLE: INCREASED SAFETY LED CEILING LIGHT (Ex db eb mb op is IIC T4 Gb) FOR MARINE USE					
CHECKED		SCALE	N/S						
DESIGN	B. I. KIM	COLOR	N-9.3						
DATE	2015.12.04	IP	66/67						
				MODEL NO.	EXLED-125ed-550UWM16UF2HC40-R10	WEIGHT	6.3 Kg		
				DWG NO.	L71370295	SHEET NO.	5		

OS-E1UF

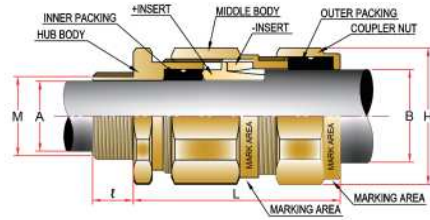

Application : Any Type of Armoured Cable

- For use with any type of armoured cable
- Outdoor & Indoor use
- Flameproof & Increased Safety
- EMC cable gland. (360 ° contact) - EMC tested
- Reduce the effect of coldflow characteristics
- Double compression

Design Specification	BS 6121, IEC 62444, EN 50262
Compliance Standard	IEC/EN 60079-0, 1, 7, 31
ATEX Certification	Presafe 17 ATEX 11456X
IECEx Certification	IECEx PRE 17.0063X
Code of Protection	II2G Ex db IIC Gb, Ex eb IIC Gb, II2D Ex tb IIIC Db
Operating Temperature	-60°C ~ 110°C
Regulation	Zone 1, 2, 21&22, Gas Group IIA, IIB and IIC
Ingress Protection	IP 66 / 67 IP68 available when requested only
Applicable Cable Specification	All types of armoured cable
Gland Material	Nickel plated brass(standard), Brass(only), Stainless steel(316L), Aluminum
Gasket (washer)	Nylon(Standard), PTFE-Teflon(Option)
Packing	Silicone
Accessories (optional)	Lock nut, Sealing washer, Earth tag, Shroud, Serrated washer

Order Example

Part No.	Thread	Material	Accessories
OS-E1UF 20	M20	Nickel plated brass	Lock nut, Sealing washer, Earth tag, Serrated washer, Shroud

• Optional Thread Length : ≥15mm (Standard : M16 ~ M63 Length 15mm, M75 Length 20mm, M90 ~ M115 Length 25mm)

• Material for accessories is required

BS 6121 Type of Gland (The suffix for each type of protection)

Single wire armoured	W
Wire braided	X
Aluminium strip armoured	Y
Double steel tape armoured	Z



Part No.	Entry Thread Size(M)			Minimum Thread Length(ℓ)			Cable Dia		Armour Size		Hexagon Dimensions	Weight (g)	Length (L)
	Metric	NPT	Option	Metric	NPT	Option	Inner 'A'	Outer 'B'	Wire	Braid			
OS-E1UF 16	M16	1/2"	M20	15	15	15	5.0 ~ 11.5	9.0 ~ 15.5	0.9 ~ 1.25	0.05 ~ 0.8	H25 x P27	137	56
OS-E1UF 20	M20	1/2"	3/4"	15	15	16	7.5 ~ 15.2	14.0 ~ 20.5	0.9 ~ 1.25	0.05 ~ 0.8	H31 x P34	212	63
OS-E1UF 25	M25	3/4"	1"	15	16	18	13.0 ~ 19.6	17.0 ~ 26.0	1.25 ~ 1.6	0.05 ~ 0.8	H37 x P40	325	68
OS-E1UF 32	M32	1"	1-1/4"	15	18	19	16.5 ~ 26.2	24.0 ~ 33.5	1.6 ~ 2.0	0.05 ~ 1.2	H47 x P50	570	75
OS-E1UF 40	M40	1-1/4"	1-1/2"	15	19	21	23.0 ~ 32.3	30.0 ~ 41.5	1.6 ~ 2.0	0.05 ~ 1.2	H56 x P60	876	83
OS-E1UF 50	M50	1-1/2"	2"	15	21	24	29.0 ~ 41.5	38.0 ~ 50.0	1.8 ~ 2.5	0.05 ~ 1.2	H70 x P75	1445	89
OS-E1UF 63	M63	2"		15	24		39.0 ~ 50.0	45.0 ~ 60.0	1.8 ~ 2.5	0.05 ~ 1.2	H77 x P82	1740	98
OS-E1UF 63X	M63		2-1/2"	15		27	46.0 ~ 55.0	55.0 ~ 66.0	1.8 ~ 2.5	0.05 ~ 1.2	H82 x P88	1907	98
OS-E1UF 75	M75	2-1/2"		20	27		52.0 ~ 61.0	58.0 ~ 72.0	1.8 ~ 2.5	0.05 ~ 1.2	H92 x P100	3270	109
OS-E1UF 75X	M75		3"	20		30	59.0 ~ 67.0	66.1 ~ 79.0	1.8 ~ 2.5	0.05 ~ 1.2	H98 x P106	2912	109
OS-E1UF 90	M90	3"	3-1/2"	25	30	32	66.0 ~ 80.0	72.0 ~ 90.0	1.8 ~ 3.0	0.05 ~ 1.6	H110 x P120	4600	111
OS-E1UF 100	M100	3-1/2"	4"	25	32	32	76.0 ~ 90.5	84.0 ~ 101.5	1.8 ~ 3.0	0.05 ~ 1.6	H125 x P135	5500	123
OS-E1UF 115	M115	4"		25	32		88.0 ~ 102	100 ~ 116	1.8 ~ 3.0	0.05 ~ 1.6	H135 x P143	5500	123

※ The entry holes need not greater than 0.7mm

※ Up to M75, 1.5 pitch is standard and from M90, 2.0 pitch is standard